

Swivel combination Mod. I...

Material: aluminium.

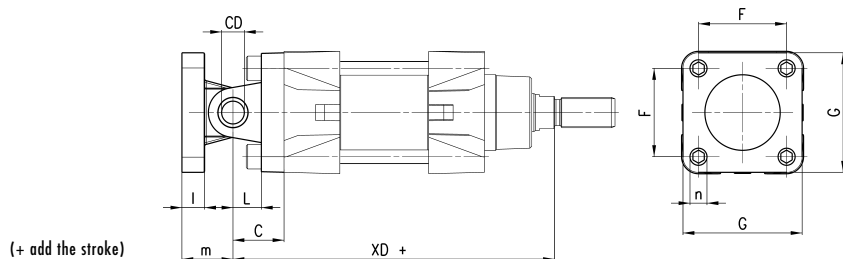
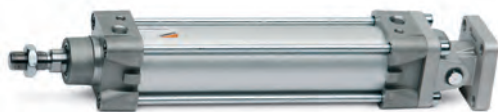

DIMENSIONS										
Mod.	∅	CD ^{H9}	L	C	XD ± 1.6	F	G	l	m	n
I-41-32	32	10	12	22	142	32,5	45	10	22	6,5
I-41-40	40	12	15	25	160	38	52	10	25	6,5
I-41-50	50	12	15	27	170	46,5	63	12	27	9
I-41-63	63	16	20	32	190	56,5	73	12	32	9
I-41-80	80	16	24	36	210	72	95	12	36	11
I-41-100	100	20	29	41	230	89	115	12	41	11
I-41-125	125	25	30	50	275	110	135	20	50	13

90° male trunnion according to CETOP RP 107P Mod. ZC...

CETOP RP 107P.
Material: aluminium.

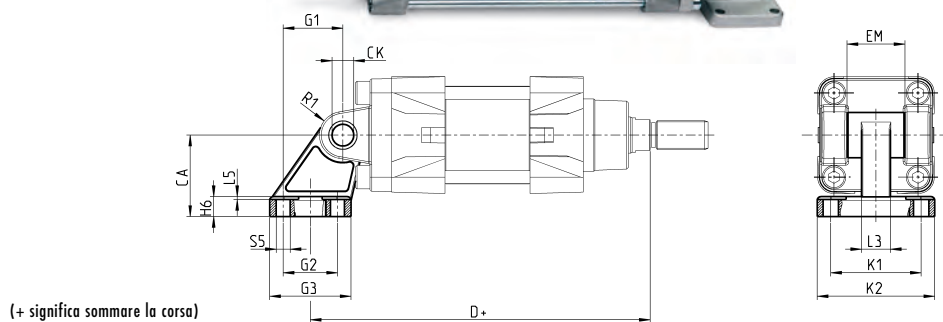
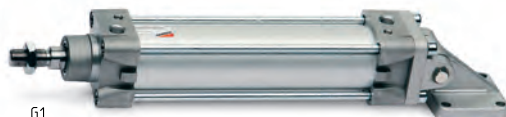

DIMENSIONS																	
Mod.	∅	M	CK	S5	d	K1	K2	L3	G1	L5	G2	EM	G3	CA	H6	R1	
		H13	H9	H13		JS14	MAX	MAX	JS14	MAX	JS14		SJ14	JS15		MAX	
ZC-32	32	11	10	6,6	154	38	51	10	21	1,6	18	26		31	32	8	10
ZC-40	40	11	12	6,6	173	41	54	15	24	1,6	22	28	-0,2	35	36	10	11
ZC-50	50	15	12	9	188	50	65	16	33	1,6	30	32	-0,6	45	45	12	13
ZC-63	63	15	16	9	209,5	52	67	16	37	1,6	35	40		50	50	12	15
ZC-80	80	18	16	11	237	66	86	20	47	2,5	40	50		60	63	14	15
ZC-100	100	18	20	11	260	76	96	20	55	2,5	50	60	-0,5	70	71	15	19
ZC-125	125	20	25	14	315	94	124	30	70	3,2	60	70	-1,5	90	90	20	22,5

